

MODEL 103A
DC VOLTAGE STANDARD
OPERATION MANUAL

印刷表紙使用のこと

KIKUSUI ELECTRONICS CORP.

Power Requirements of this Product

Power requirements of this product have been changed and the relevant sections of the Operation Manual should be revised accordingly.

(Revision should be applied to items indicated by a check mark)

Input voltage

The input voltage of this product is _____ VAC,
and the voltage range is _____ to _____ VAC. Use the product within this range only.

Input fuse

The rating of this product's input fuse is _____ A, _____ VAC, and _____.

WARNING

- To avoid electrical shock, always disconnect the AC power cable or turn off the switch on the switchboard before attempting to check or replace the fuse.
- Use a fuse element having a shape, rating, and characteristics suitable for this product. The use of a fuse with a different rating or one that short circuits the fuse holder may result in fire, electric shock, or irreparable damage.

AC power cable

The product is provided with AC power cables described below. If the cable has no power plug, attach a power plug or crimp-style terminals to the cable in accordance with the wire colors specified in the drawing.

WARNING

- The attachment of a power plug or crimp-style terminals must be carried out by qualified personnel.



CONTENTS

1.	GENERAL	3
2.	SPECIFICATIONS	3
3.	HOW TO OPERATE	5
	3.1 Explanations on Front and Back Panels	5
	3.2 Preparations for Operation	8
	3.3 How to Use Sampling Terminal	8
	3.4 Notes for Operation	10
4.	WORKING PRINCIPLE	11
5.	MAINTENANCE	13
	5.1 How to Remove Case	13
	5.2 Layout	14
	5.3 Adjustment and Correction	19
	5.4 Repairing	21
	5.5 Circuit Diagram	

1. GENERAL

Kikusui Denshi DC Voltage Standard, Model 103A is a regulated DC power supply that enables obtaining the set dial value of $0 \sim \pm 100V$ DC, $0 \sim 100mA$, with an accuracy of 0.05%. It is fully transistorized, small-sized and lightweight.

The output voltage of $0 \sim 100V$ can be produced in 3 decimal digits and the desired voltage by using a fine adjustment dial and a range switch. The voltage range can be varied 0.0005% by means of the fine adjustment dial.

Output current is automatically controlled by an electronic protection circuit when it exceeds the rated value due to a short circuit or other overload. The overload is indicated by a lamp.

This equipment is used for various purposes such as research, inspection, quality control, maintenance of electronic equipment, etc., as a correction device of general DC voltmeters, power source of DC bridges, standard voltage of potentiometers, precision constant voltage power supply and so forth.

2. SPECIFICATIONS

DC voltage standard

Model	103A
Output voltage	0 to ± 100 V
Range	± 1 V, ± 10 V, ± 100 V, 3 ranges
Polarity switch	positive or negative
Accuracy	± 0.05 % of setting or ± 0.02 % of range, whichever is greater

Output current	0 to 100 mA
Sampling terminal	Provided on front panel
Overload protection	Automatic crossover type
Ripple and noise	Less than $200 \mu\text{V}_{\text{RMS}}$ (5 Hz to 1 MHz)
Load regulation	Less than $\pm 0.002\%$ of range or $100 \mu\text{V}$ whichever is greater against no load to full load change.
Line regulation	Less than $\pm 0.002\%$ of range or $100 \mu\text{V}$ whichever is greater against $\pm 10\%$ line voltage change
Power source	-----V 50/60 Hz Approx. 32 VA
Dimensions	200(W) x 140(H) x $\frac{330}{320}$ (D)
(Largest part)	200(W) x $\frac{155}{160}$ (H) x $\frac{370}{355}$ (D)
Weight	Approx. 4.6 Kg
Accessories	Short bar 2
	Operation manual 1
	Test data 1

3. HOW TO OPERATE

3.1 Explanations on Front and Back Panels

(Refer to Figures 3-1, 2.)

- (1) POWER: Push-type power switch of alternate operation. Power is switched on and a pilot lamp is lighted when this is locked by pressing it.
- (2) RANGE: Knob for selecting ranges. Figures 1V, 10V and 100V show the maximum voltages of respective set ranges, and the position of decimal point moves according to the switching of range.
- (3) Voltage setting dials: Used to set the output voltage. When turned clockwise, the output increases. 3 dials vary in the range of 0 ~ 9 respectively.
- (4) VERNIER: By varying this knob in the range of 0 ~ 10, a varied output corresponding to one graduation on the lowest digit dial is obtained; therefore the maximum voltage at each voltage range can be obtained by setting all 3 dials at 999 and then turning this knob fully clockwise.
- (5) POLARITY: Switch for the polarity of output

voltage and standby. When on "+", the output terminal (red) is positive polarity, and when on "-", the output terminal (red) is negative polarity.

- (6) OUTPUT SAMPLING terminal: Output terminal of DC voltage, by which an output of 0 ~ 100V, 0 ~ 100mA can be obtained. OUTPUT terminal is connected with the load by a current terminal. SAMPLING terminal is used for the so-called remote sensing. It is used generally by connecting it with the current terminal and a short bar.
- (7) OVERLOAD: When output current of more than about 110mA flows, this indicator lamp comes on and the current is limited. When the overload is eliminated, the lamp goes out automatically.
- (8) Fuse: 0.5A fuse inserted in the primary side of power transformer. The bracket can be removed by turning it counterclockwise.
- (9) Power cord: Used for connecting the power the ___V AC, 50/60 Hz.
- (10) Cord roll: The power cord is rolled on it when this equipment is not used.

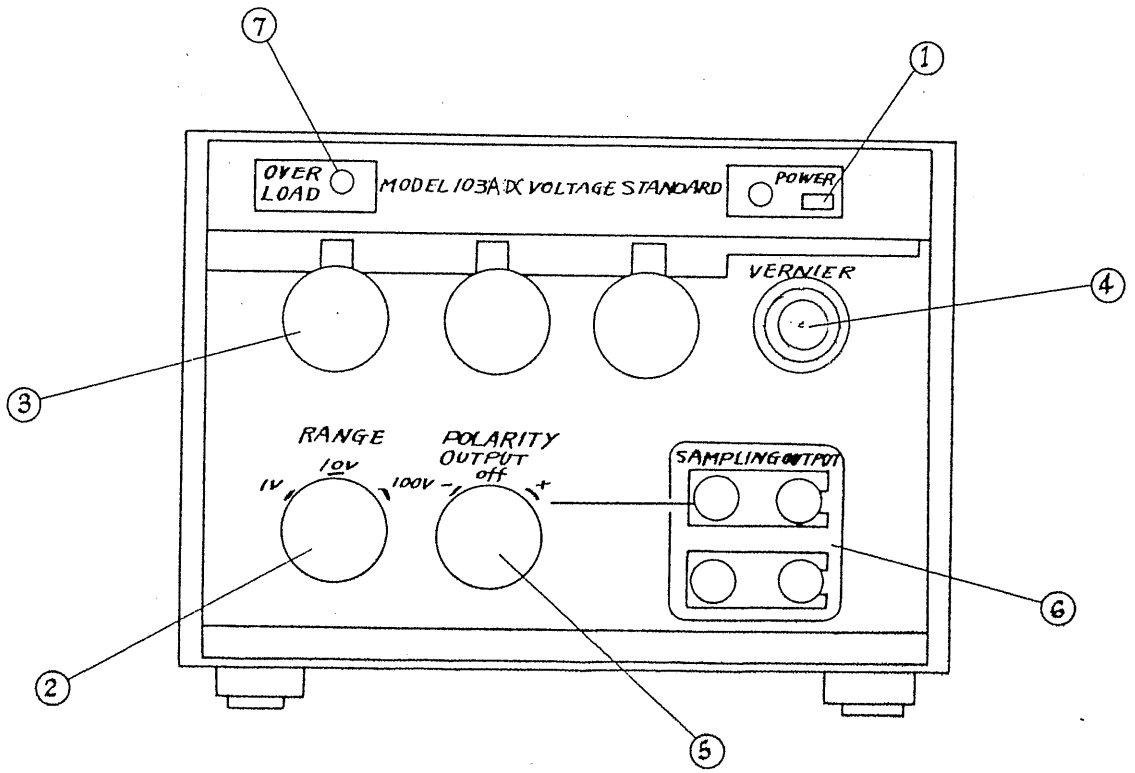

Fig. 3-1

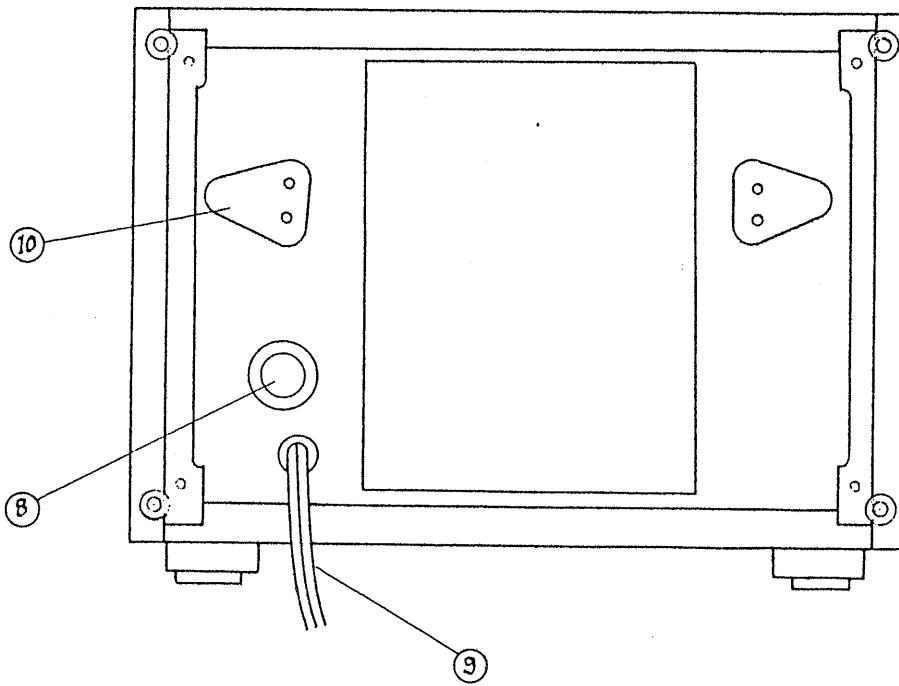

Fig. 3-2

3.2 Preparations for Operation

1. Set all the output voltage setting dials on "0", and put the polarity switch at OFF.
2. Connect the AC cord to the power source of 100V AC, 50/60 Hz, and then switch POWER on.
3. As this equipment employs a thermostatic oven for the standard power source, it should be warmed up for more than 30 minutes. However, when voltage accuracy is not required, it can be operated a few seconds after the power is switched on.

3.3 How to Use Sampling Terminal

This SAMPLING terminal is used when there is a long distance between the equipment and the load, and when the load terminal is required to be at the set voltage.

The error when not employing the SAMPLING terminal as shown in Figure 3-3, is as follows.

Error voltage ΔE is,

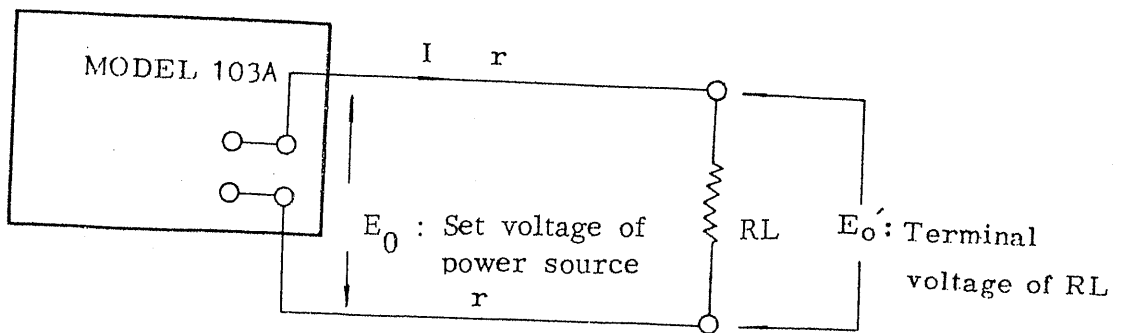

r: One side electrical resistance from

the power source to the load

$$E = E_0 - E_0 = I(RL + 2r) - I \cdot RL$$

RL: Load resistance

$$\therefore E = 2r I \quad (1)$$

ΔE : Error voltage due to r

Where the output voltage is 1V, and the lead wire resistance is 0.5Ω at one side, the terminal voltage of the load when the load current of 100mA flows is 0.9V as shown by the following expression, resulting in a 0.1V error.

$$E_0 = 1V - 2 \times 0.5 \times 100 \times 10^{-3} = 0.9V$$

The SAMPLING terminal was provided so as to eliminate such a voltage drop due to the lead wire.

The SAMPLING terminal is connected with the load terminal for voltage detection, after the short bar is removed, as shown in Figure 3-4.

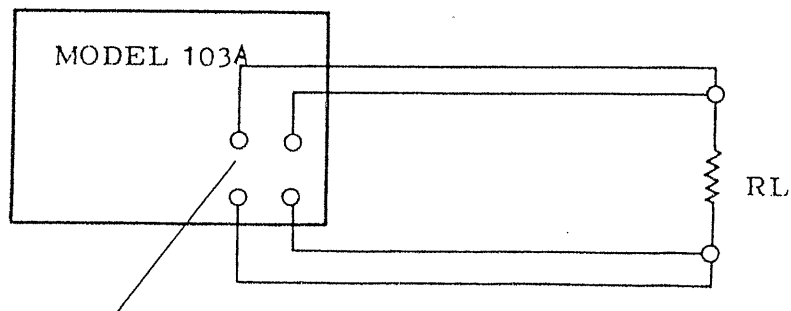

Figure 3-4 Removal of the short bar

Fig. 3-4

3.4 Notes for Operation

This equipment is so constructed that the internal chassis is floating in the case, and it is connected to the red-colored output terminal when the polarity switch is on "+", and to the white output terminal when the polarity switch is on "-". Thus it has electric potential, so utmost care must be taken in handling it when the case is opened.

The short bar belonging to the output sampling terminal should be fixed tightly without fail when this terminal is not in use.

If it is loose, accurate output voltage cannot always be obtained.

4. WORKING PRINCIPLE

Figure 4-1 below shows the block diagram of DC Voltage Standard, Model 103A.

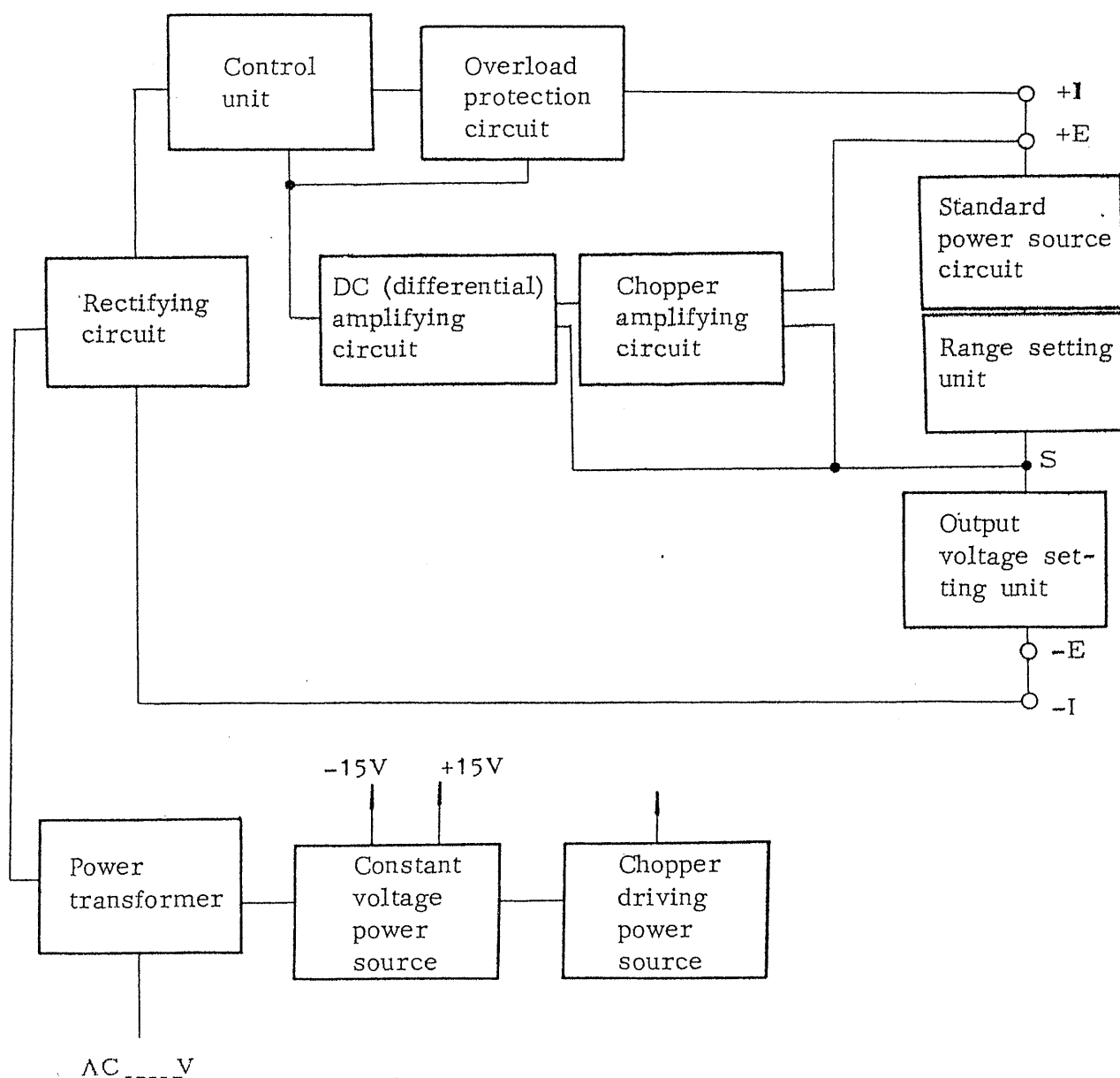

Fig. 4-1

In Figure 4-1, +1 and -1 show the current output terminals, and +E and -E show output detection terminals (SAMPLING).

Presuming that the current terminal was connected with the load, or the voltage of the voltage detection terminal dropped due to a change in 100V AC power, the electric potential of S (addition point of the standard power and the output terminal) will rise, and the DC amplifier and chopper amplifier will amplify this error signal, controlling it to the direction where the collector signal of the control transistor increases.

As a result of said control, the drop of output voltage is compensated, restoring it to the state before the voltage dropped.

The chopper amplifier compensates the drift of DC amplifier that is provided for improving the transient characteristics of the circuit.

The chopper which employs a MOSFET having excellent offset voltage drives a square wave of about 220 Hz.

In order to improve the operating stability of this equipment, a metal film resistor having a low temperature coefficient is employed for setting output voltage and range, and a temperature compensation type zener diode is put in the thermostatic oven for the standard power source.

The range is selected by changing the current for the output voltage setting resistor, by means of replacing the above-mentioned resistor.

The selection of output voltage is done by varying the said resistor.

The protection circuit of output current controls the maximum output

current through the detection of voltage drop of the resistor that is sued in series with the control transistor.

5. MAINTENANCE

5.1 How to Remove Case

Remove the 4 screws shown in Figure 5-1, take off the foot at the back, and pull backward slowly the two side panels, upper panel and base panel.

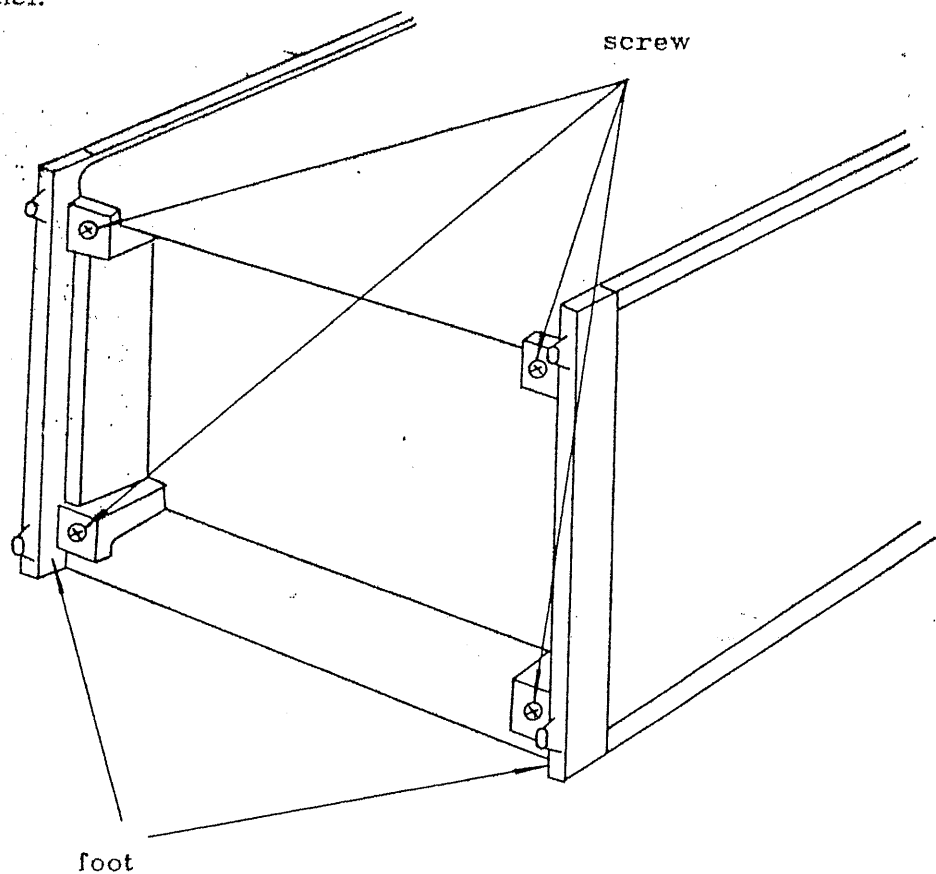

Fig. 5-1

N.B. Note that if the case is slanted forward with a handle in the state without the foot at the back, the upper panel separates from the frame.

5.2 Layout

The overall layout is shown in Figure 5-2, and the component layouts of each printed circuit board are shown in Figures 5-3 ~ 6.

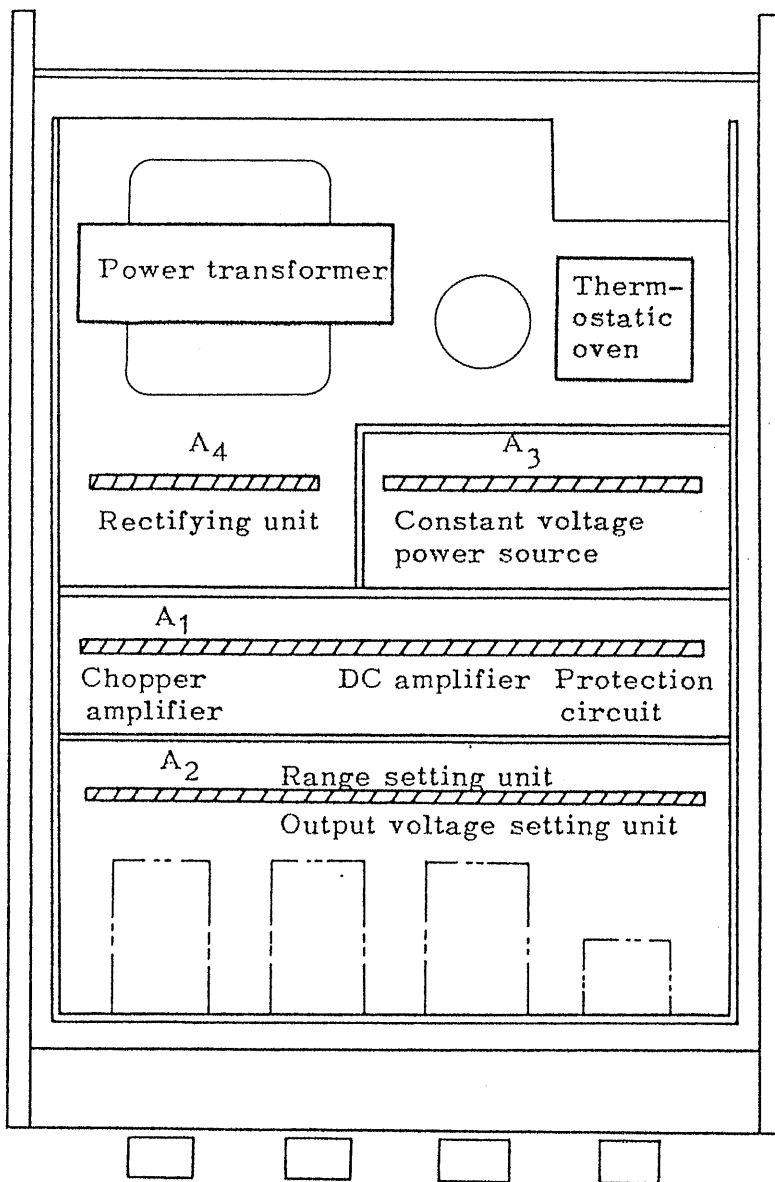

Fig.5-2

Printed circuit board A₁: DC amplifier, Chopper amplifier and Protection circuit

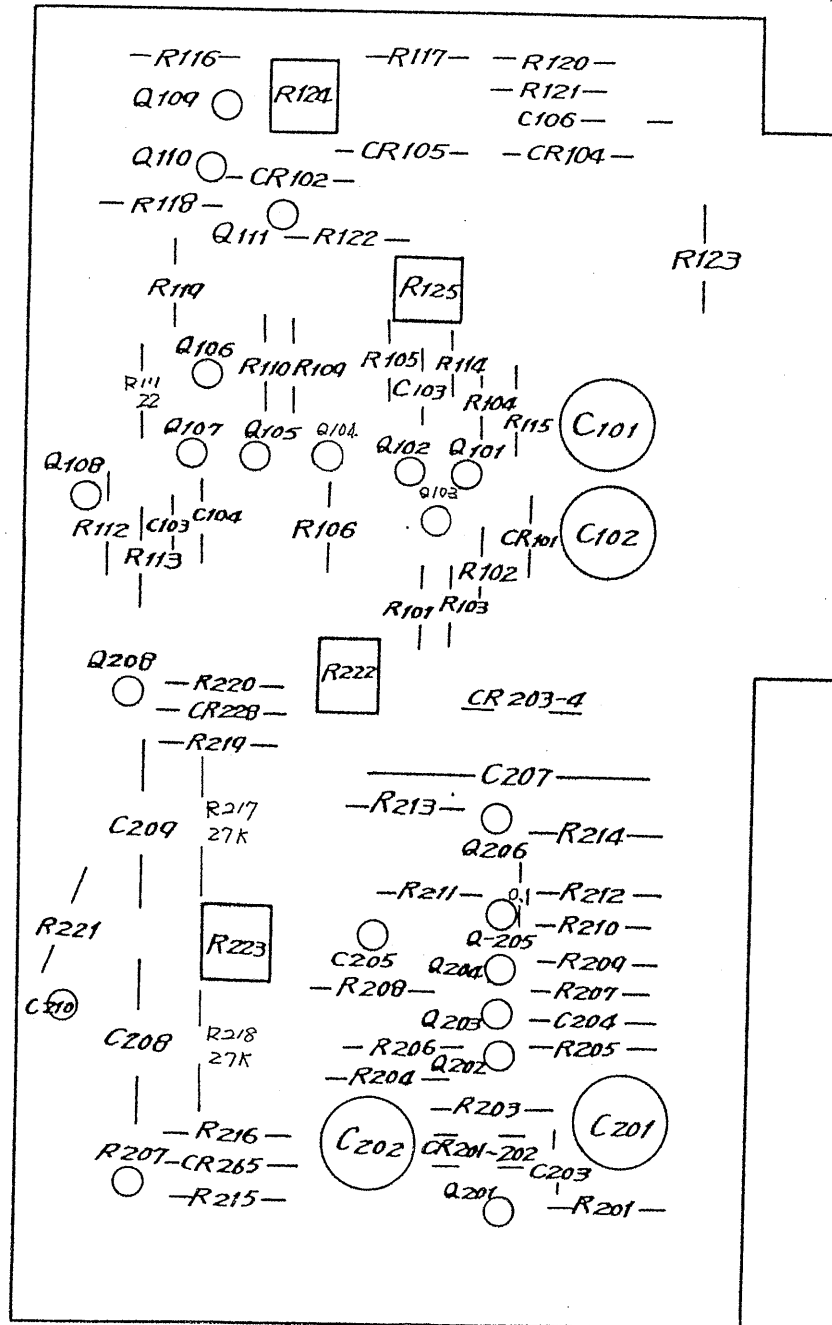

Fig. 5-3

Printed circuit board A₂: Range setting unit

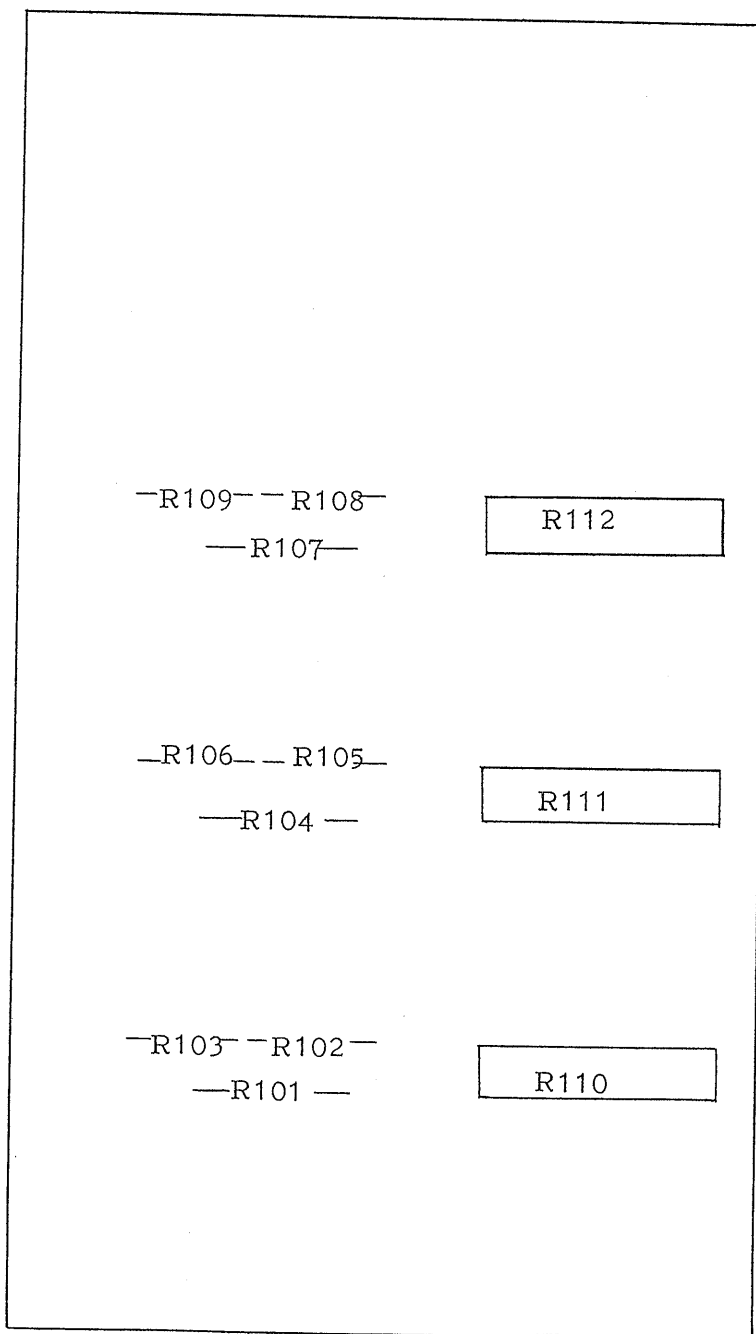

Fig. 5-4

Printed circuit board A₃: Constant voltage power supply unit

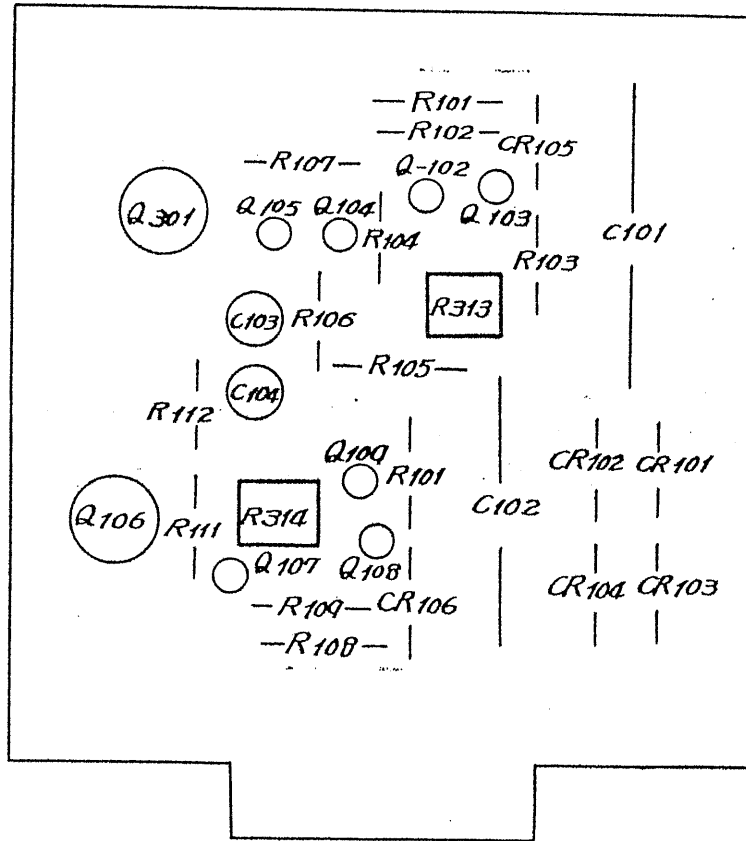

Fig. 5-5

Printed circuit board A₄: Rectifying unit

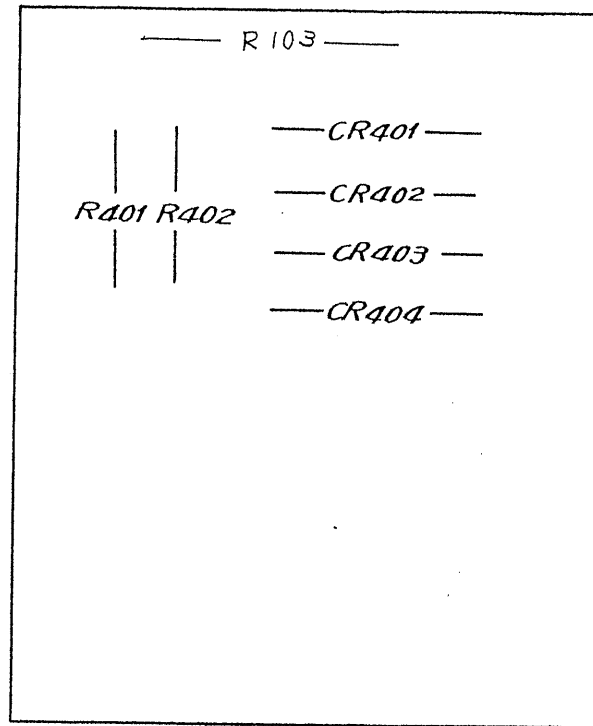

Fig. 5-6

5.3 Adjustment and Correction

In order to maintain the accurate operation of this equipment for a long time, it is recommended to inspect, adjust and correct it periodically; for instance, once every six to twelve months is desirable.

The correction will be done at a place where the ambient temperature is about 25°C constantly, from the viewpoint of accuracy of correction.

This equipment will be adjusted and corrected according to the following processes, after being warmed up for more than one hour.

1. Adjustment of constant voltage power +15V

Connect a DC voltmeter with the connector pins No. 5(OV) and 2 of the printed circuit board A_3 , and adjust the variable resistor R_{313} so as to make it match +15V.

2. Adjustment of constant voltage power -15V

Connect a DC voltmeter with the connector pins No. 5 and 3 of the printed circuit board A_3 , and adjust the variable resistor R_{314} so as to make it match -15V.

3. Adjustment of astable multivibrator

Connect an oscilloscope with Q208 (collector) and ground (connector pin No. 4) of the printed circuit board A_1 , and adjust the variable resistor R_{223} so as to secure symmetrization of the square wave.

Next, connect an electronic counter with the same points and make the oscillating frequency match 220 Hz, by using the variable

resistor R_{222} .

4. Adjustment of output voltage OV (at 1V range)

Set each dial and the fine adjustment knob on "0", and the polarity switch at "+". Next, connect a DC voltmeter (with sensitivity better than 1.5mV F.S.) with the output terminal, and make it match OV by using the variable resistor R_{125} (printed circuit board A_1).

5. Correction of 1V range (printed circuit board A_2)

Set the range switch at the 1V range, and turn the fine adjustment knob fully clockwise after setting each dial at 999. Measure the output voltage by using a precision potentiometer or a differential voltmeter having accuracy better than 0.01%, and make it match 1,000V by using R_{112} .

6. 10V range (printed circuit board A_2)

Leaving the dials and knob as they are, set the range switch at the 10V range and make it match 10.000V by means of R_{111} .

7. 100V range (printed circuit board A_2)

Leaving the dials and knob as they are, set the range switch at the 100V range and make it match 100.00V by means of R_{110} .

8. Adjustment of protection circuit

Set the range switch at the 100V range, connect a variable load resistor to the output, and increase the current up to

110mA using R_{124} so that the lamp showing OVER LOAD is put on.

5.4 Inspection and Repairing

For inspection and repairing of this equipment refer to "4 WORKING PRINCIPLE". The voltages in the following tables are examples measured with 0V as the standard.

The operating condition of this equipment is no-load operation at the 100V range, with the maximum output. The measured values were obtained by using a VTVM with 11-M Ω internal resistance.

1. Chopper amplifier (printed circuit board A₁)

Transistor	Collector (V)	Base (V)	Emitter (V)
α 202	7.5	- 0.65	0.6
203	0.58	0.6	0.1
204	0.63	0.58	0
205	3.8	0.63	0.1

2. Astable multivibrator

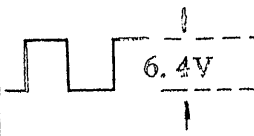
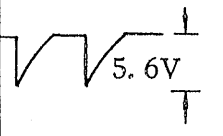
Transistor	Collector	Base	Emitter
α 207			DC - 6.5 V

3. DC amplifier (printed circuit board A₁)

Transistor	Collector (V)	Base (V)	Emitter (V)
Q 101	5.9	0	1.59
102	5.9	0	
103	1.59	-7.5	-8.1
104	12.4	5.9	5.2
105	11	5.9	5.2
106	15	12.4	11.7
107	5.4	11	11.7
108	15	1.7	1.0

4. Protection circuit (printed circuit board A₁)

Transistor	Collector (V)	Base (V)	Emitter (V)
Q 109	1.7	-1.9	-0.6
110	14.6	0	-0.6
111	15	-0.6	0

5. Constant voltage circuit (printed circuit board A₃)

Transistor	Collector (V)	Base (V)	Emitter (V)
Q 101	33	16	15
102	33	16.8	16
103	16.8	29	29.5
104	16.8	8.8	8.2
105	15	8.8	8.2
106	-15	-34.6	-35
107	-34.6	-16	-15
108	-16	-30	-30.6
109	-16	-0.64	0